

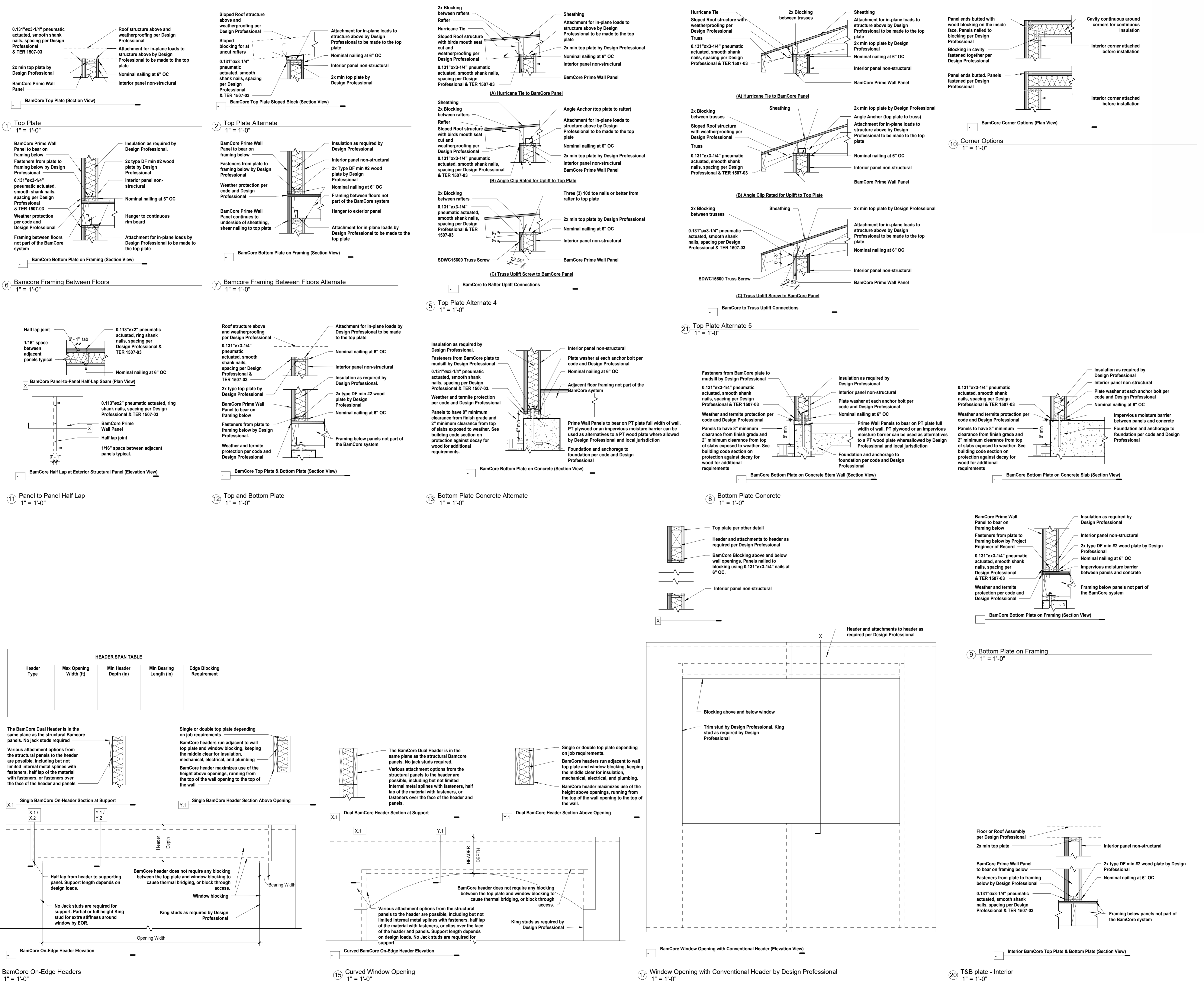

BAMCORE

www.bamcore.com



HEADER SPAN TABLE

Header Type	Max Opening Width (ft)	Min Header Depth (in)	Min Bearing Length (in)	Edge Blocking Requirement

Typical BamCore Details (Monoshear)

Project Number: _____ Project Number: 8/29/2024
 Date: 8/29/2024
 Drawn By: MM
 Checked By: NA

1

Scale: 1" = 1'-0"

9/12/2024 6:05:28 PM



BAMCORE®

www.bamcore.com

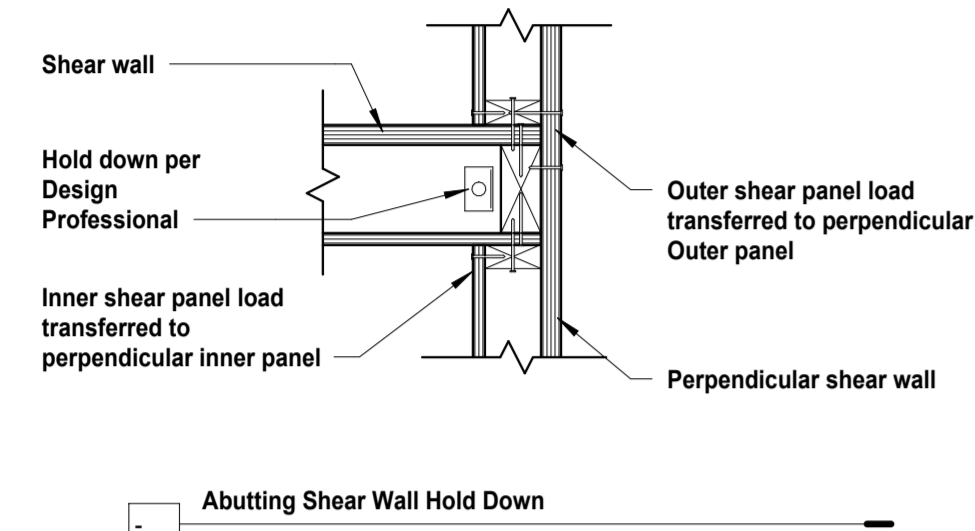

1 Abutting Hold downs
1" = 1'-0"

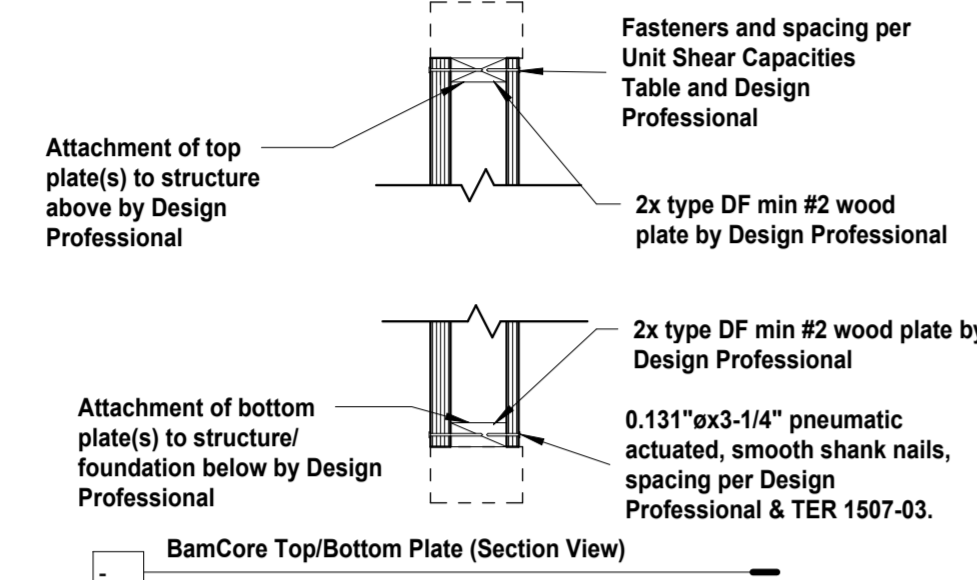

2 Top/Bottom Plate only
1" = 1'-0"

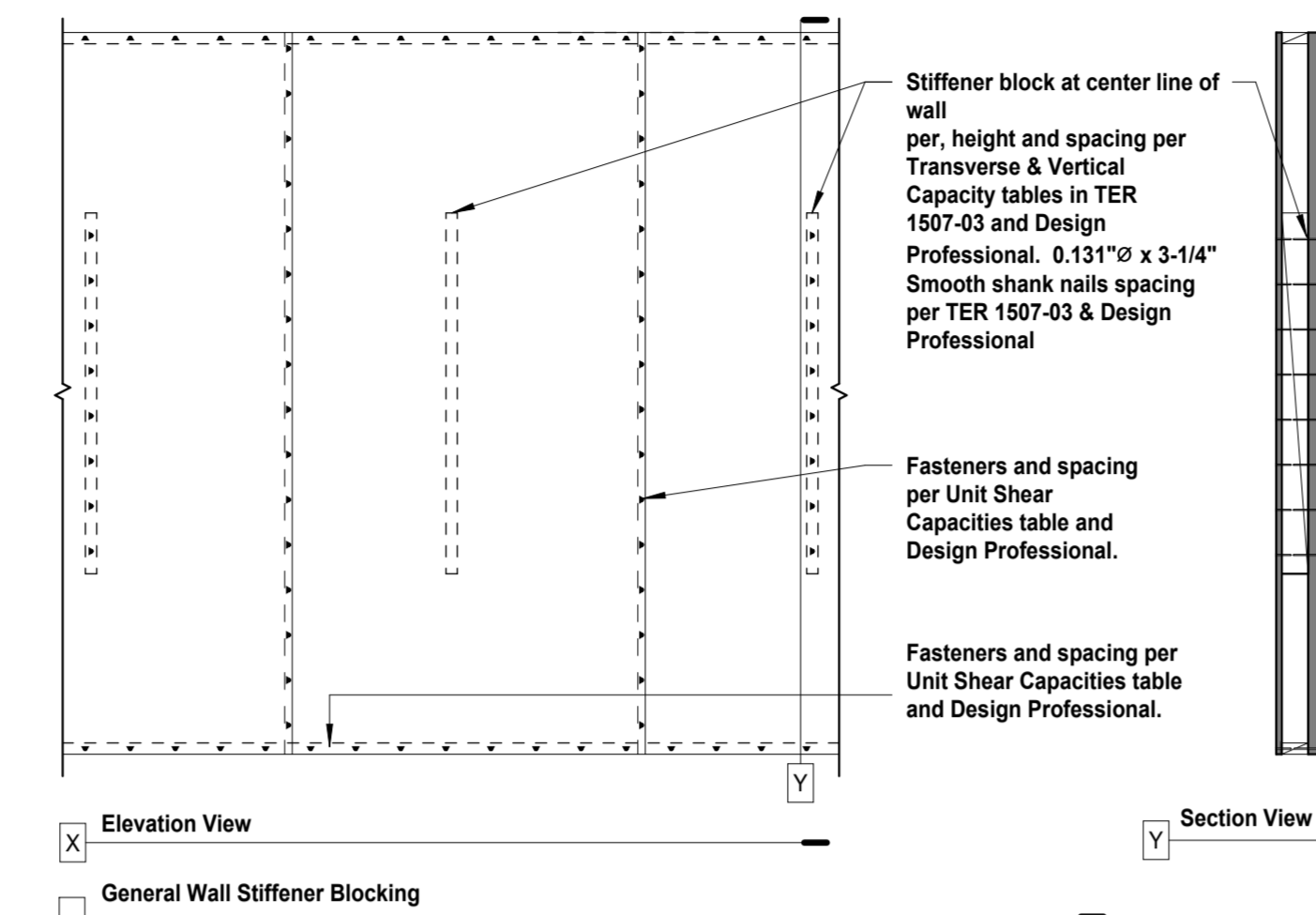

3 General Wall Stiffener Blocking
1/2" = 1'-0"

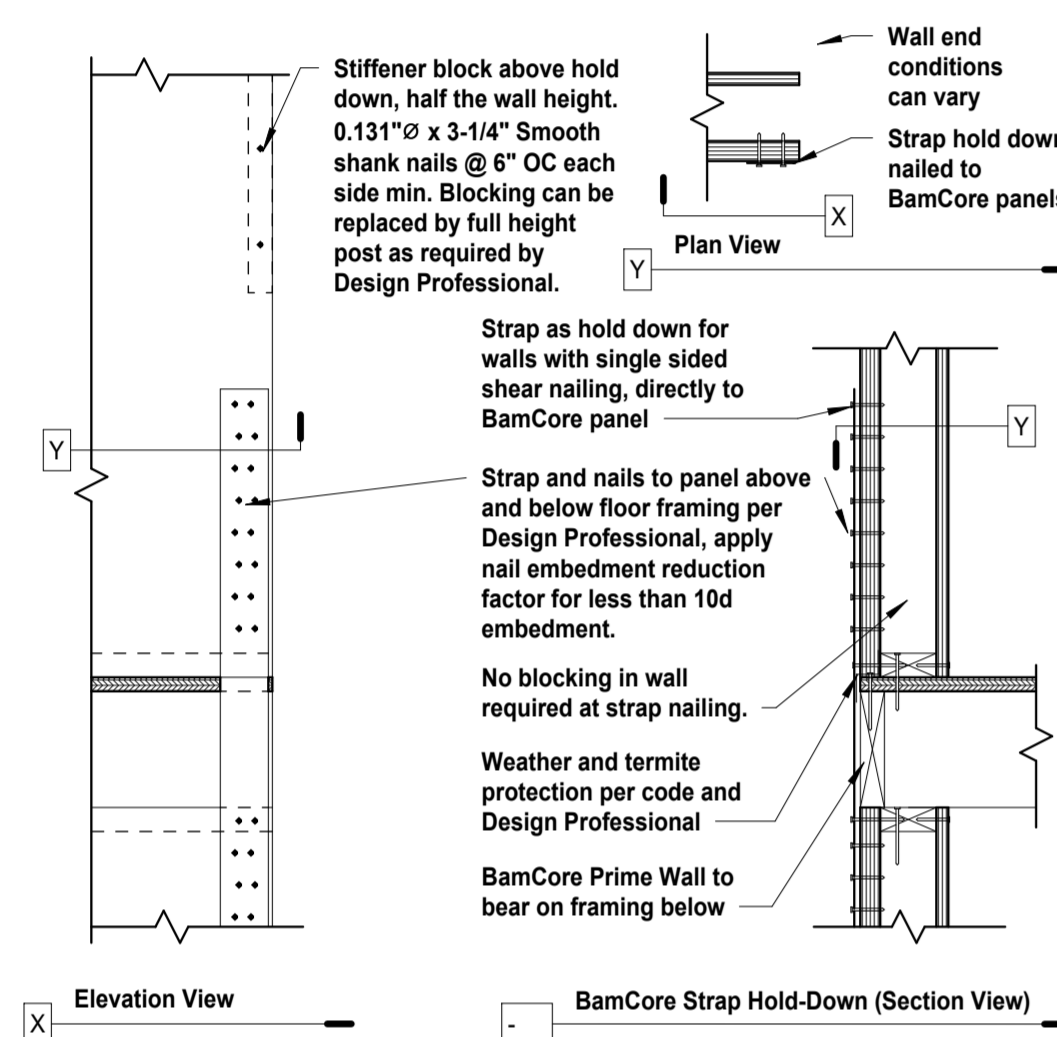

6 Strap Hold-Down to BamCore Panel
1" = 1'-0"

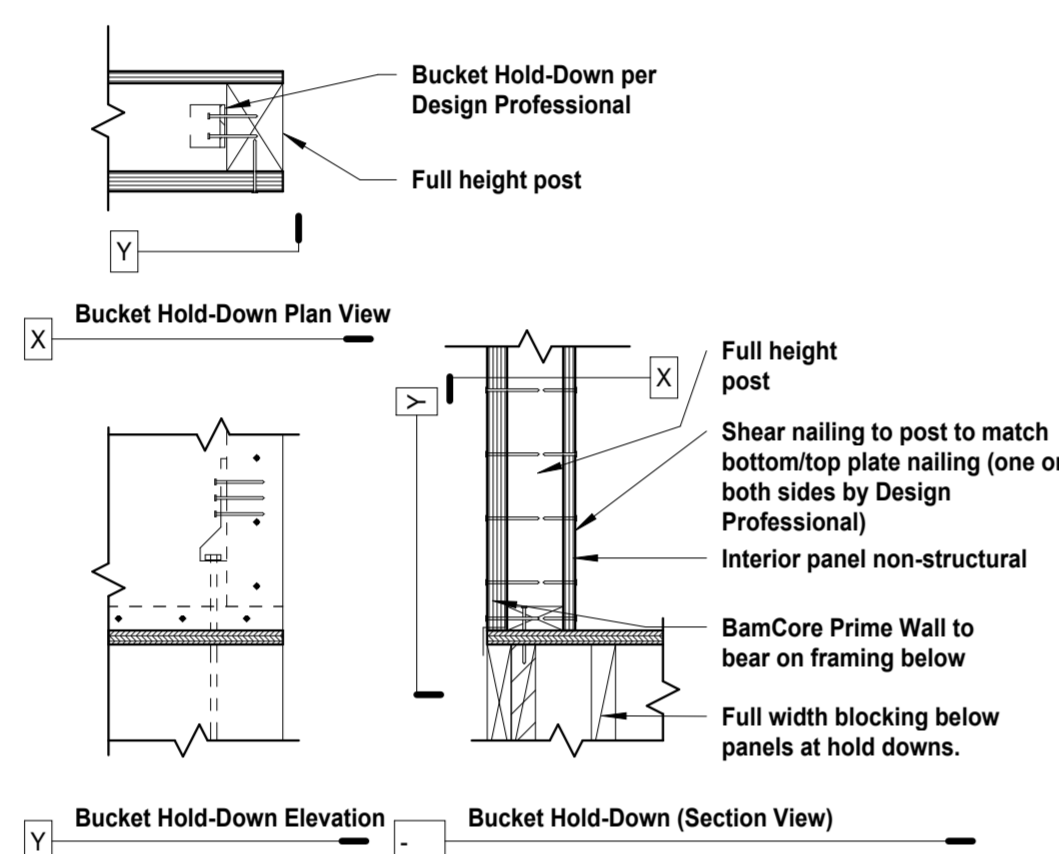

7 Bucket Hold-Down to BamCore Panel
1" = 1'-0"

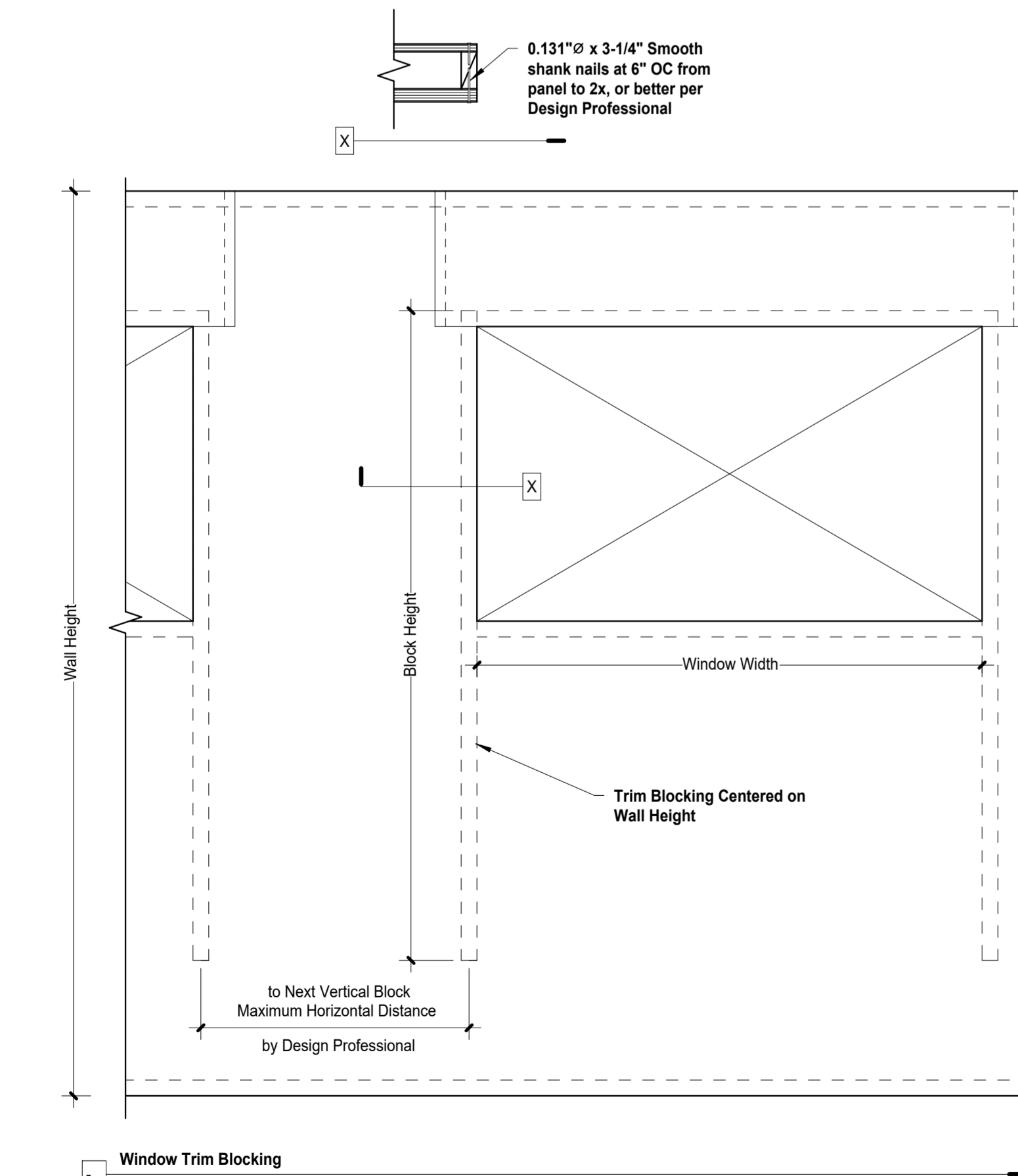

9 Window Trim Blocking
1" = 1'-0"

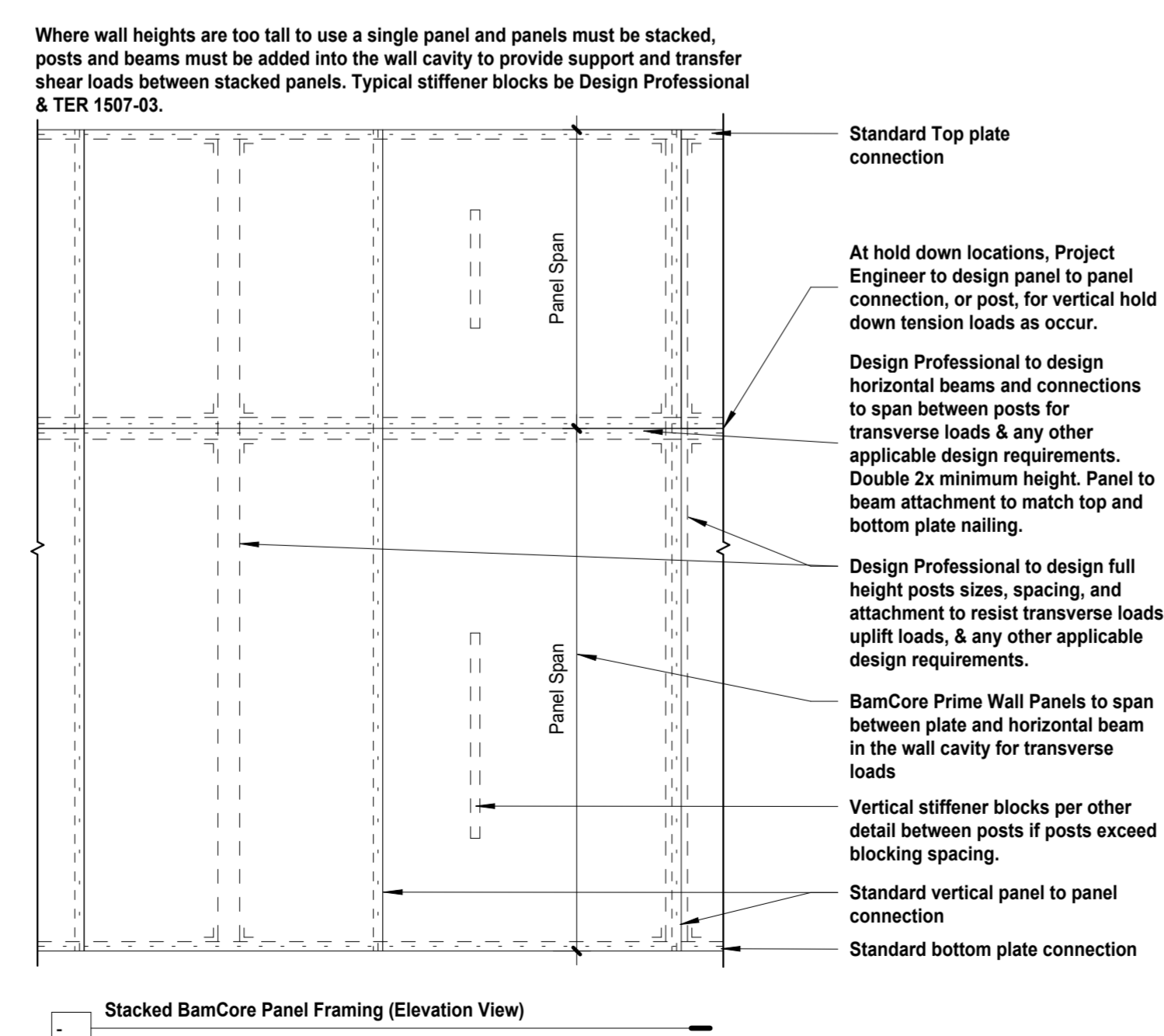

10 Tall Wall Framing
1/2" = 1'-0"

Typical BamCore Details (Monoshear)

Project Number	Project Number
Date	8/29/2024
Drawn By	JB
Checked By	NA

2

Scale As indicated